

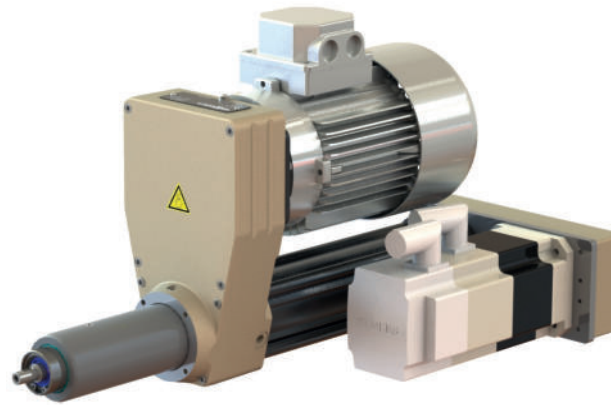

unità cnc

DU10E.50

Feed Avanzamento	balls screw $\varnothing 16 \times 5$ vite a sfere $\varnothing 16 \times 5$
Working stroke Corsa utile	50 mm 50 mm
Drilling Capacity Capacità di foratura	$\varnothing 10$ on steel Rm50 $\varnothing 10$ su acciaio Rm50
Max thrust Spinta massima	1500 N 153 Kg
Spindle speed Velocità mandrino	from 500 to 9000 rpm da 500 a 9000 g/1'
Motor Power Potenza Motore	from 0.37 to 1.1 Kw da 0.37 a 1.10 Kw



- Advance by ball screw $\varnothing 16 \times 5$, preloaded nut to "0" back lash.
- Spindle concentricity 0,01.
- N. 3 magnetic switches REED PNP-NO (1): front, rear and "0" position.
- Working stroke 50mm.
- Feed servomotor not included (2).
- Predisposition for customer's servomotor (3).
- Servomotor-ball screw transmission (4) by thoused belt HTD, ratio 1:1 or 1:2.
- Servomotor torque:
ratio 1:1 max 1,5N/m
ratio 1:2 max 0,75N/m
- Standard color: Beige RAL 1001.
Other colors on request.
- Weight from 12 Kg

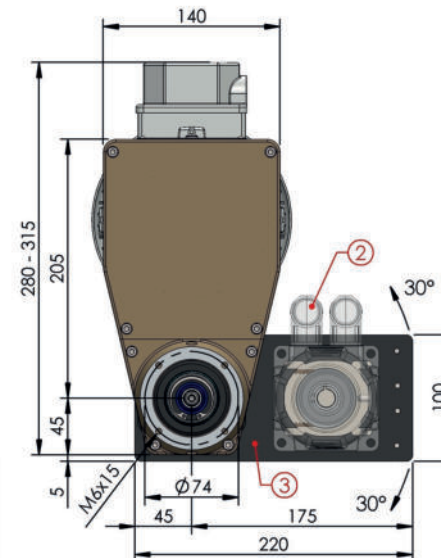
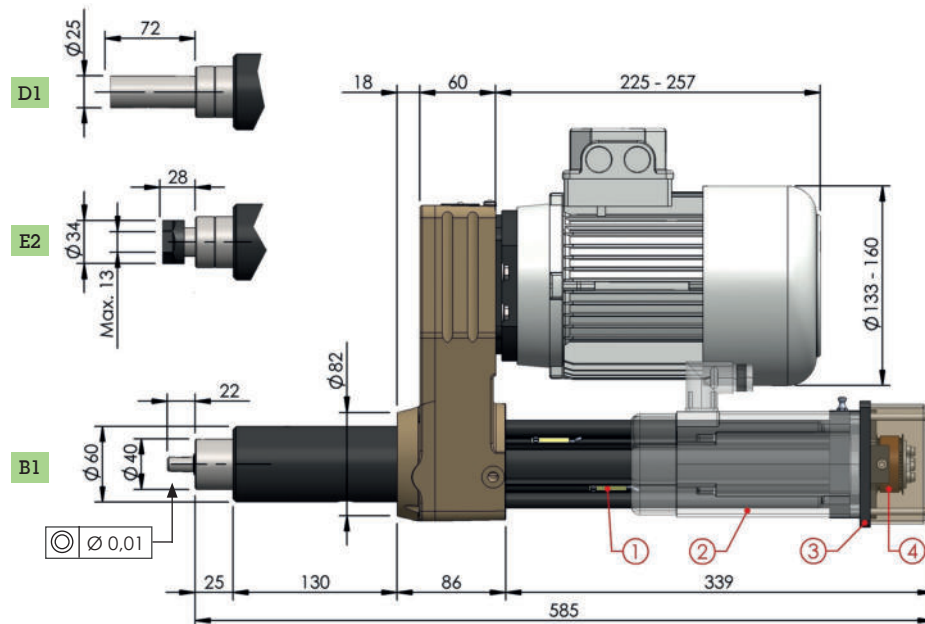

- Avanzamento con vite a ricircolo di sfere $\varnothing 16 \times 5$, chiocciola precaricata a gioco "0".
- Concentricità mandrino 0,01.
- N. 3 sensori magnetici REED PNP-NO (1): fine corsa posizione "0", fine corsa avanti, fine corsa indietro.
- Corsa utile 50mm.
- Servomotore avanzamento non fornito (2).
- Predisposizione per servomotore cliente (3).
- Trasmissione servomotore-vite (4) con cinghia dentata HTD, rapporto 1:1 o 1:2.
- Coppia servomotore:
rapporto 1:1 max 1,5N/m
rapporto 1:2 max 0,75N/m
- Colore standard: Beige RAL 1001.
Altri colori su richiesta.
- Peso da 12 Kg

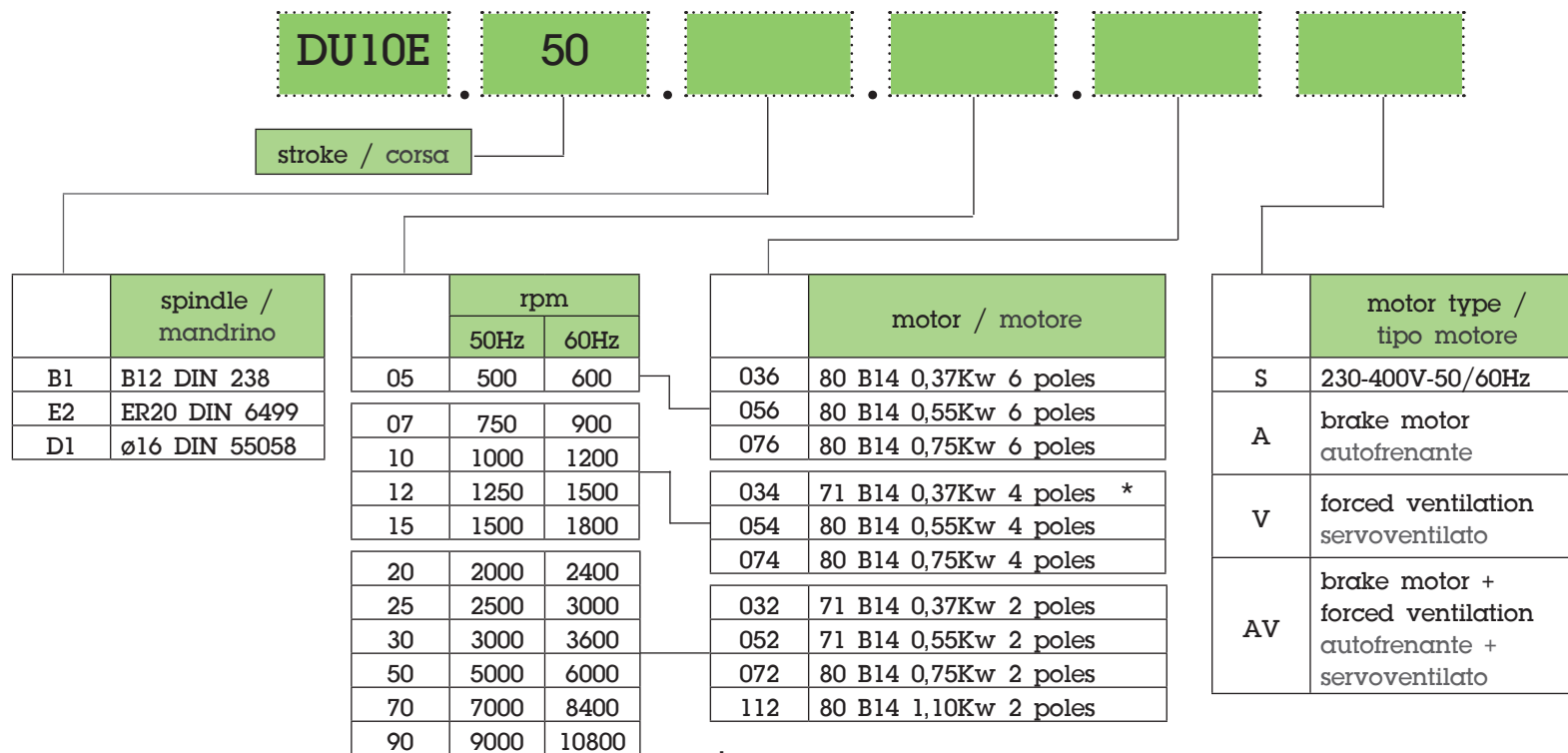

* Not available for speed 07
Non disponibile per velocità 07

STANDARD COLOR



OPTIONAL COLORS

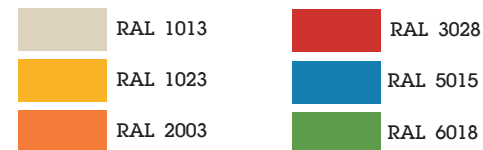

optional :

accessories for easy installation
accessori per una facile installazione

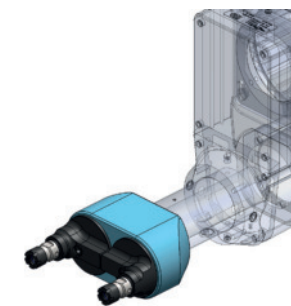
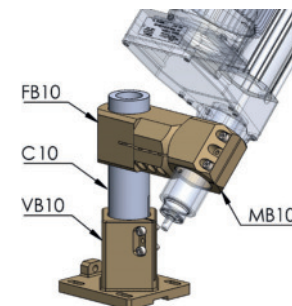
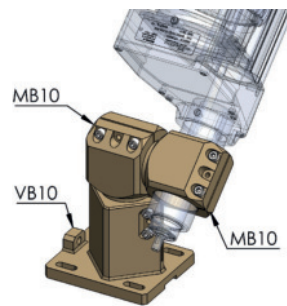
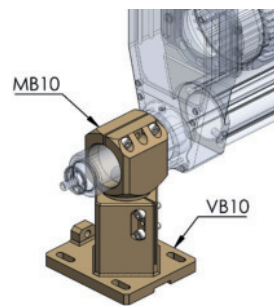
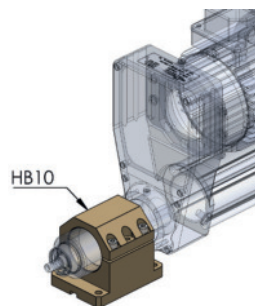

multispindle head
teste multiple