



DU20P 100

stroke / corsa

	spindle / mandrino
C2	MT2 DIN 228
E5	ER25 DIN 6499
E3	ER32 DIN 6499
D2	ø20 DIN 55058

	rpm	
	50Hz	60Hz
01	100	120
02	200	240
03	300	360
05	500	600
07	700	840
08	800	960
11	1100	1320
15	1500	1800
22	2200	2640
30	3000	3600
45	4500	5400

	motor / motore
80...	motor reducer 0,75Kw 4 poles
81...	motor reducer 1,50Kw 4 poles
076	90 B14 0,75Kw 6 poles
116	90 B14 1,10Kw 6 poles
156	100 B14 1,50Kw 6 poles
226	112 B14 2,20Kw 6 poles
074	80 B14 0,75Kw 4 poles
114	90 B14 1,10Kw 4 poles
154	90 B14 1,50Kw 4 poles
224	100 B14 2,20Kw 4 poles
304	100 B14 3,00Kw 4 poles
072	80 B14 0,75Kw 2 poles
112	80 B14 1,10Kw 2 poles
152	90 B14 1,50Kw 2 poles
222	90 B14 2,20Kw 2 poles
302	100 B14 3,00Kw 2 poles

	motor type / tipo motore
S	230-400V-50/60Hz
A	brake motor autofrenante
V	forced ventilation servoventilato
AV	brake motor + forced ventilation autofrenante + servoventilato

	hydrocheck / regolatore
75H	standard
75HS	with oil bowl con serbatoio olio
100HP	peck feed scarico trucioli

STANDARD COLOR

RAL 1001

OPTIONAL COLORS

- RAL 1013
- RAL 3028
- RAL 1023
- RAL 5015
- RAL 2003
- RAL 6018

optional :

accessories for easy installation  
accessori per una facile installazione

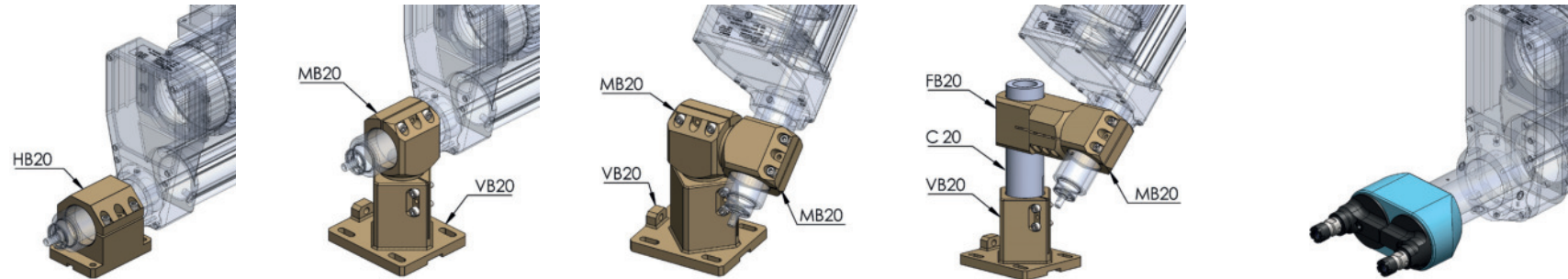

multispindle head  
teste multiple