

# drill & tap units



## unità di foratura/maschiatura

### FM10P.100

Feed Avanzamento	pneumatic pneumatico
Stroke Corsa	100 mm 100 mm
Tapping Capacity Capacità di maschiatura	M10 on steel Rm50 M10 su acciaio Rm50
Thrust at 6 bar Spinta a 6 bar	1200 N 122 Kg
Spindle speed Velocità mandrino	from 500 to 3000 rpm da 500 a 3000 g/l'
Motor Power Potenza Motore	from 0.37 to 1.10 Kw da 0.37 a 1.10 Kw

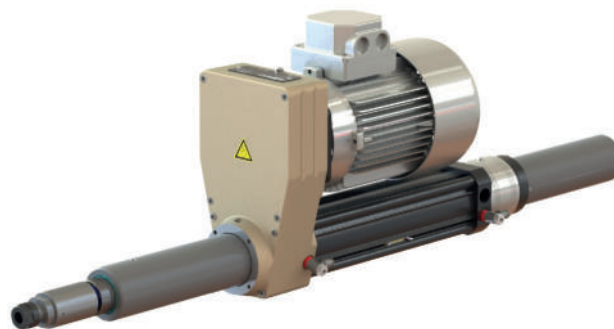

- Pneumatic cylinder ø63.
- Air inlet ø6 (1).
- Air consumption 2,20NL/ciclo.
- Spindle concentricity 0,01.
- Electric wires connections M16x1,5 (4).
- Internal limit switches (3)
- Magnetic sensor to change spindle speed (2).
- Feed hydrocheck (6) in line with spindle.
- Hydrocheck stroke 75mm.
- Fast/slow stroke separately adjustable (5).
- Toolholder for collet ER16 with axial compensation + 15mm (7).
- Standard color: Beige RAL 1001.  
Other colors on request.
- Weight from 15 Kg



- Cilindro pneumatico ø63.
- Ingressi aria ø6 (1).
- Consumo 2,20NL/ciclo.
- Concentricità mandrino 0,01.
- Ingresso cavi elettrici M16x1,5 (4).
- Fine corsa di posizione elettrici interni (3).
- Sensore magnetico per cambio velocità (2).
- Regolatore idraulico di avanzamento (6) in linea con il mandrino.
- Corsa del regolatore idraulico 75mm.
- Corse rapido/lento regolabili separatamente (5).
- Mandrino portapinzza ER16 con compensazione assiale + 15mm (7).
- Colore standard: Beige RAL 1001.  
Altri colori su richiesta.
- Peso da 15 Kg

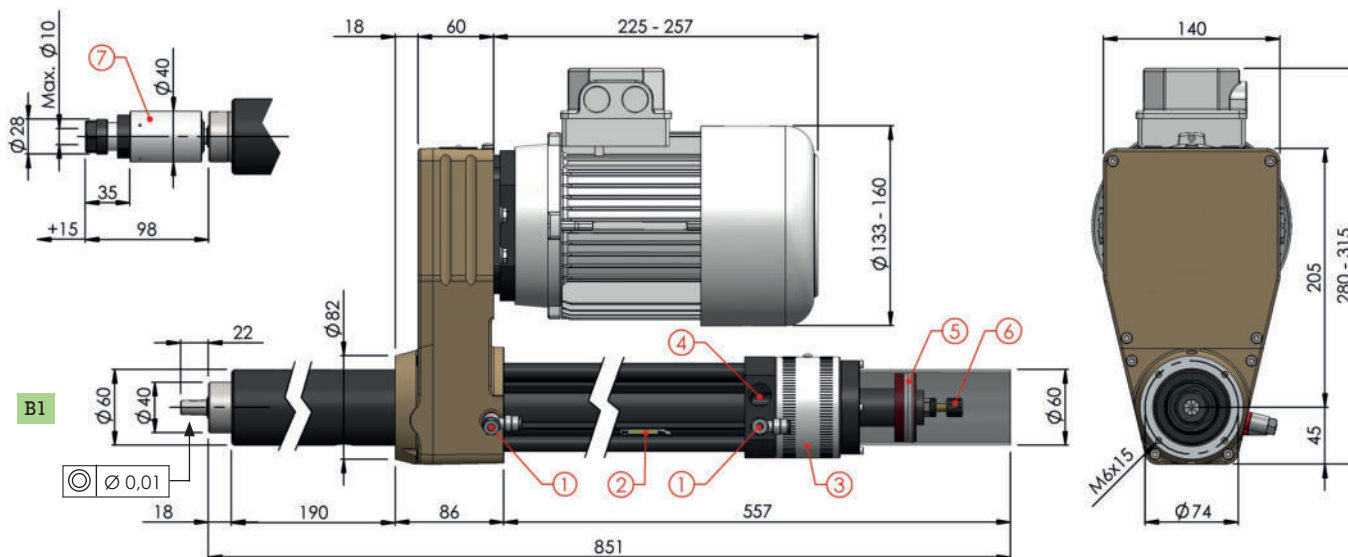

FM10P

100

stroke / corsa

spindle / mandrino	
B1	B12 DIN 238

	rpm	
	50Hz	60Hz
05	500	600
07	750	900
10	1000	1200
12	1250	1500
15	1500	1800
20	2000	2400
25	2500	3000
30	3000	3600

motor / motore	
036	80 B14 0,37Kw 6 poles
056	80 B14 0,55Kw 6 poles
076	80 B14 0,75Kw 6 poles
034	71 B14 0,37Kw 4 poles *
054	80 B14 0,55Kw 4 poles
074	80 B14 0,75Kw 4 poles
032	71 B14 0,37Kw 2 poles
052	71 B14 0,55Kw 2 poles
072	80 B14 0,75Kw 2 poles
112	80 B14 1,10Kw 2 poles

motor type / tipo motore	
S	230-400V-50/60Hz
V	forced ventilation servovenilato

hydrocheck / regolatore	
75H	standard
75HS	with oil bowl con serbatoio olio

053	71 B14 0,55/0,37Kw 2/4poles
083	80 B14 0,80/0,60Kw 2/4poles
113	80 B14 1,10/0,80Kw 2/4poles

\* Not available for speed 07  
Non disponibile per velocità 07

STANDARD COLOR



OPTIONAL COLORS

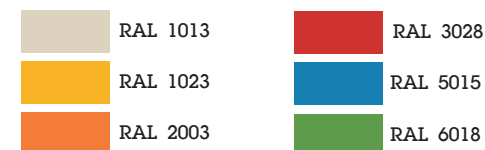

optional :

accessories for easy installation  
accessori per una facile installazione

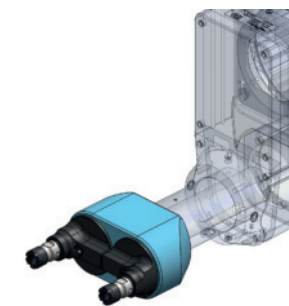
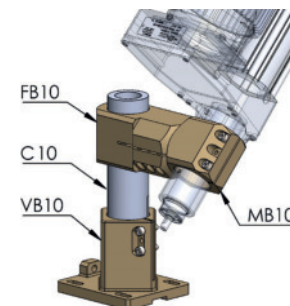
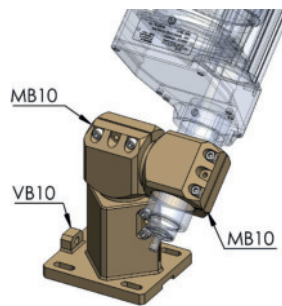
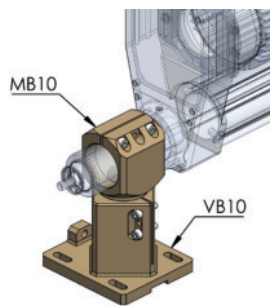
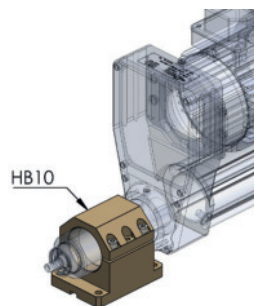

multispindle head  
teste multiple