

# slide units



## slitte di avanzamento

### SL30P.125

Feed	pneumatic
Avanzamento	pneumatico
Stroke	125 mm
Corsa	125 mm
Thrust at 6 bar	2700 N
Spinta a 6 bar	275 Kg

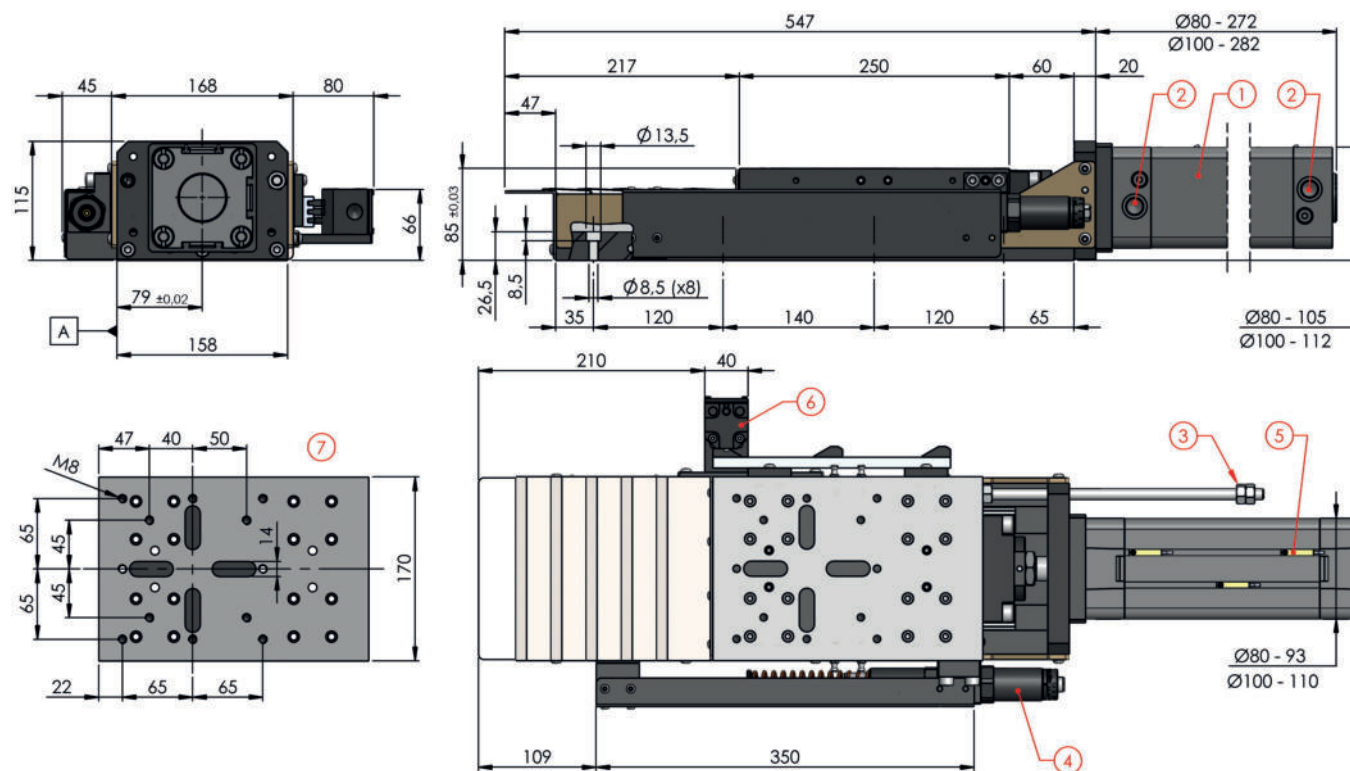
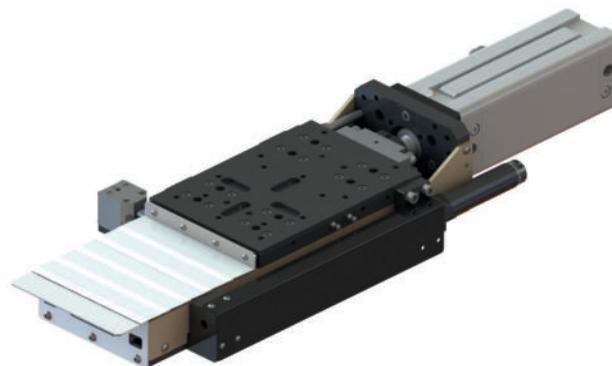

- Pneumatic slide unit.
- Pneumatic cylinder ø80 (1).  
Optional: pneumatic cylinder ø100.
- Air inlet (2):  
cylinder ø80 G3/8 - cylinder ø100 G1/2.
- Air consumption at 6bar:  
cylinder ø80 8,8NL/cycle  
cylinder ø100 13,7NL/cycle.
- Adjustable mechanical stop (3).
- Fast/slow stroke separately adjustable.
- Hydrocheck stroke 75mm (4).
- Front bellows cover.
- Magnetic sensors on cylinder (5).  
Optional: 3 contacts limit switches (6).
- Rearranged to install unit SU20 - SU30 (7).
- Standard color: Beige RAL 1001.  
Other colors on request.
- Weight from 40 Kg



- Unità di avanzamento pneumatica.
- Cilindro pneumatico ø80 (1).  
Su richiesta cilindro pneumatico ø100.
- Ingressi aria (2):  
cilindro ø80 G3/8 - cilindro ø100 G1/2.
- Consumo aria a 6bar:  
cilindro ø80 8,8NL/ciclo  
cilindro ø100 13,7NL/ciclo.
- Battuta meccanica regolabile (3).
- Corse rapido/lento regolabili separatamente.
- Regolatore idraulico corsa 75mm (4).
- Soffietto lamellare anteriore.
- Sensori magnetici sul cilindro (5).  
Optional: Fine corsa di posizione  
a 3 contatti (6).
- Predisposta per installazione mandrini  
SU20 - SU30 (7).
- Colore standard: Beige RAL 1001.  
Altri colori su richiesta.
- Peso da 40 Kg

SL30P

125

stroke / corsa

	row pads / pattini
S	ball row pads pattini a sfere
R	roller pads pattini a rulli

	cylinder / cilindro
08	ø 80
10	ø 100

	limit switches position / posizione fine corsa
MR	magnetic sensor on cylinder, hydrocheck on right side. sensori magnetici sul cilindro, regolatore sul lato destro.
ML	magnetic sensor on cylinder, hydrocheck on left side. sensori magnetici sul cilindro, regolatore sul lato sinistro.
R	cam+switches on right side, hydrocheck on left side. fine corsa sul lato destro, regolatore sul lato sinistro.
L	cam+switches on left side, hydrocheck on right side. fine corsa sul lato sinistro, regolatore sul lato destro.

	front safety guard / protezione anteriore
1	with bellow cover con soffiello lamellare

	rear safety guard / protezione posteriore
0	without safety guard senza protezione

	hydrocheck / regolatore
75H	standard

STANDARD COLOR



RAL 1001

OPTIONAL COLORS



RAL 1013



RAL 3028



RAL 1023



RAL 5015



RAL 2003



RAL 6018

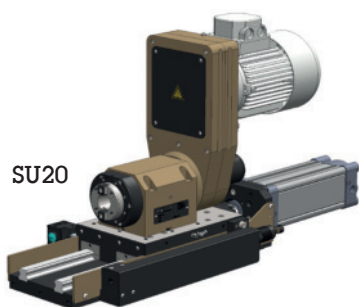

SU20

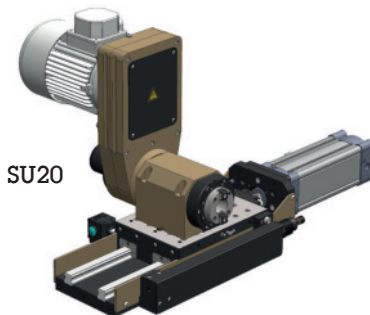

SU20

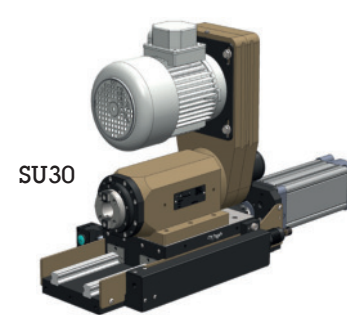

SU30

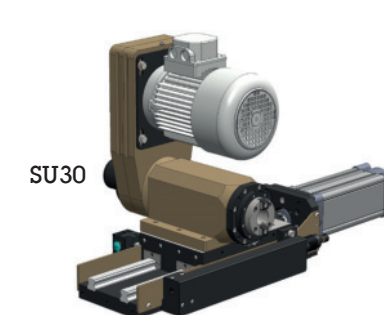

SU30