



### SU45

Drilling Capacity Capacità di foratura	ø45 on steel Rm50 ø45 su acciaio Rm50
Spindle Mandrino	ISO40 DIN2079 HSK63-C DIN69893
Spindle speed Velocità mandrino	from 100 to 7000 rpm da 100 a 7000 g/1'
Motor Power Potenza Motore	from 1.10 to 7.50 Kw da 1.10 a 7.50 Kw



- Working unit suitable for drilling, milling, reaming and boring.
- Taper roller bearings.  
Optional: precision angular contact ball bearings.
- Installation of motor in front/rear position (1).  
Transmission housing can be rotated on 360°.
- Spindle concentricity 0,01.
- Air inlet 0.5bar for internal spindle pressurization (2).
- Spindle with bore for toolholder drawbar (3).  
Optional: coolant through drawbar and rotary union
- Installation of multispindle head (4).
- Standard color: Beige RAL 1001.  
Other colors on request.
- Weight from 80 Kg



- Unità di lavoro idonea per foratura, fresatura, alesatura e barenatura.
- Cuscinetti a rulli conici.  
Su richiesta cuscinetti a sfere di precisione con contatti obliqui.
- Installazione motore in posizione anteriore o posteriore (1). Carter motore ruotabile a 360°.
- Concentricità mandrino 0,01.
- Ingresso aria 0,5bar per pressurizzazione interna mandrino (2).
- Mandrino forato per passaggio tirante (3).  
Su richiesta tirante forato per passaggio lubro-refrigerante e giunto rotante.
- Installazione teste multimandrino (4).
- Colore standard: Beige RAL 1001.  
Altri colori su richiesta.
- Peso da 80 Kg

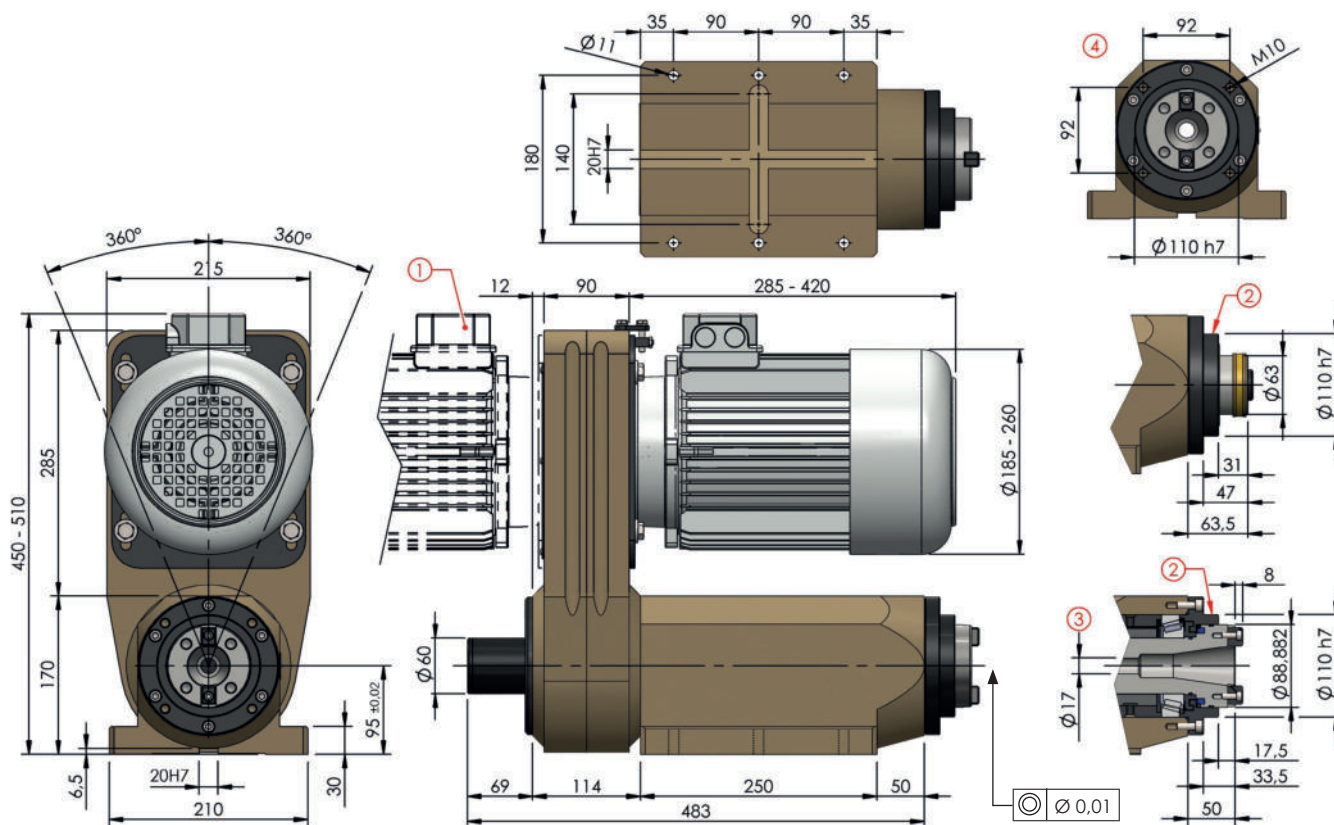

H6

S4

⊙ 0,01

# SU45

spindle / mandrino	
S4	ISO40 DIN2079
H6	HSK63-C DIN69893

bearings / cuscinetti	
T	roller bearings α rulli conici
H	precision ball bearings α sfere di precisione

	rpm	
	50Hz	60Hz
01	100	120
02	200	240
03	300	360
05	500	600
08	800	960
11	1100	1320
15	1500	1800
22	2200	2640
30	3000	3600
50	5000	6000
70	7000	8400

motor / motore	
82...	motor reducer 2,20Kw 4 poles
84...	motor reducer 4,00Kw 4 poles
116	90 B14 1,10Kw 6 poles
156	100 B14 1,50Kw 6 poles
226	112 B14 2,20Kw 6 poles
306	132 B14 3,00Kw 6 poles
406	132 B14 4,00Kw 6 poles
556	132 B14 5,50Kw 6 poles
154	90 B14 1,50Kw 4 poles
224	100 B14 2,20Kw 4 poles
304	100 B14 3,00Kw 4 poles
404	112 B14 4,00Kw 4 poles
554	132 B14 5,50Kw 4 poles
754	132 B14 7,50Kw 4 poles
152	90 B14 1,50Kw 2 poles
222	90 B14 2,20Kw 2 poles
302	100 B14 3,00Kw 2 poles
402	112 B14 4,00Kw 2 poles
552	132 B14 5,50Kw 2 poles
752	132 B14 7,50Kw 2 poles

motor type / tipo motore	
S	230-400V-50/60Hz
A	brake motor autofrenante
V	forced ventilation servoventilato
AV	brake motor + forced ventilation autofrenante + servoventilato

motor position / posizione motore	
F	front anteriore
R	rear posteriore

### STANDARD COLOR



### OPTIONAL COLORS

