

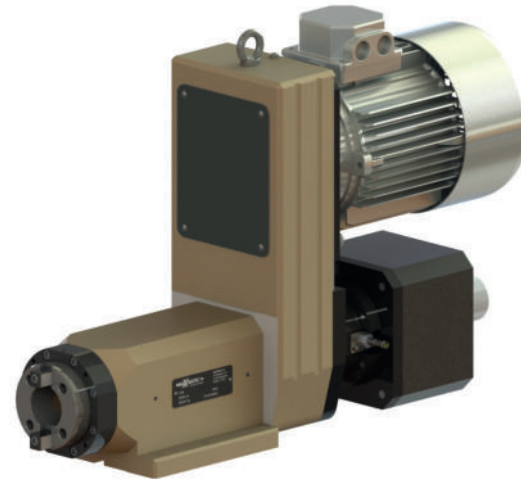

unità di lavoro

SUA30

Drilling Capacity	ø30 on steel Rm50
Capacità di foratura	ø30 su acciaio Rm50
Spindle	ISO40 DIN2079
Mandrino	ISO40 DIN2079
Clamping tool force	10,5 kN +/- 10%
Forza di bloccaggio	10,5 kN +/- 10%
Spindle speed	from 100 to 3000 rpm
Velocità mandrino	da 100 a 3000 g/1'
Axial load	max 9000 N
Carico assiale	max 9000 N
Motor Power	from 0.75 to 4.00 Kw
Potenza Motore	da 0.75 a 4.00 Kw



SPINDLE WITH AUTOMATIC TOOLHOLDER CLAMPING SYSTEM

- Working unit suitable for drilling, milling, reaming and boring.
- Prearranged for installation on slides type SL30.
- Taper roller bearings up to 4000 rpm.
Optional: precision angular contact ball bearings.
- Air inlet 0.5bar for internal spindle pressurization (1).
- Spindle concentricity 0,01.
- Clamping/unclamping or tool not present sensors (2).
- Optional: position / rotation spindle sensor (3).
- Cylinder return sensor (4).
- Rotary union for coolant / air (5). Available only on models PC and HC.
- Air/oil inlet for clamping/unclamping tool (6).
- Standard color: Beige RAL 1001.
Other colors on request.
- Weight from 48 Kg

Model	A	B
PN	145	150
PC	145	190
HN	120	115
HC	120	155

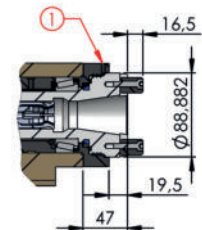
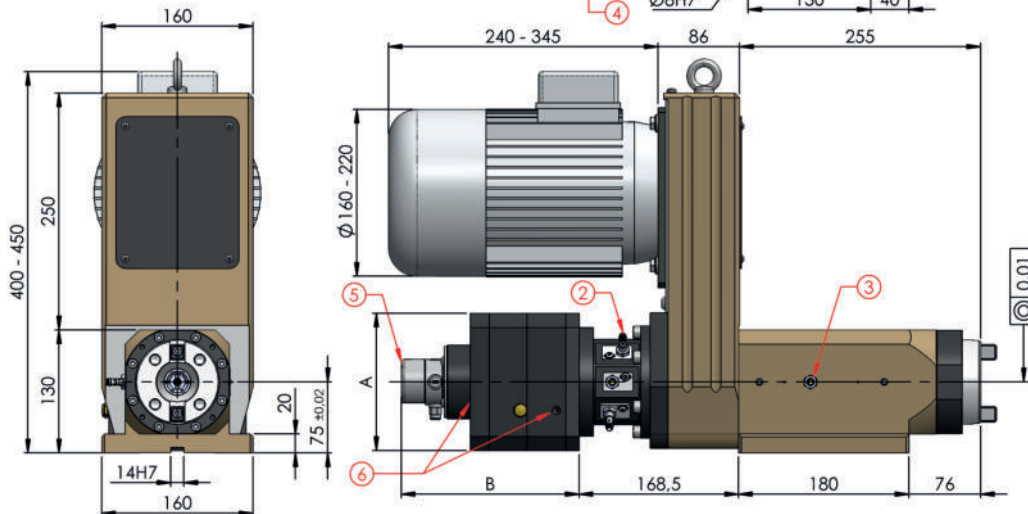
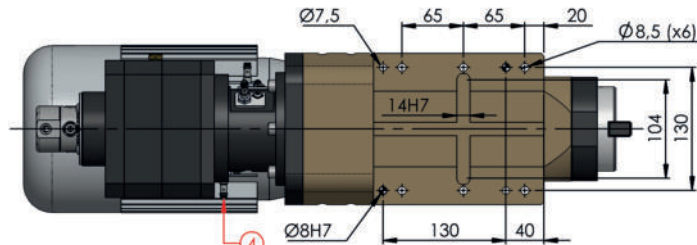

MANDRINO CON SISTEMA AUTOMATICO DI BLOCCAGGIO PORTAUTENSILE

- Unità di lavoro idonea per foratura, fresatura, alesatura e barenatura.
- Predisposta per installazione su slitte serie SL30.
- Cuscinetti a rulli conici per velocità fino a 4000 g/1'.
Su richiesta cuscinetti a sfere di precisione con contatti obliqui.
- Ingresso aria 0,5bar per pressurizzazione interna mandrino (1).
- Concentricità mandrino 0,01.
- Sensori per rilevamento bloccaggio, sbloccaggio o utensile non presente (2).
- Optional: sensore posizione/rotazione mandrino (3).
- Sensore posizione ritorno cilindro (4).
- Giunto rotante per lubrorefrigerante/aria (5).
Disponibile solo per versioni PC e HC.
- Ingressi aria/olio 1/8G per blocco/sblocco utensile (6).
- Colore standard: Beige RAL 1001.
Altri colori su richiesta.
- Peso da 48 Kg



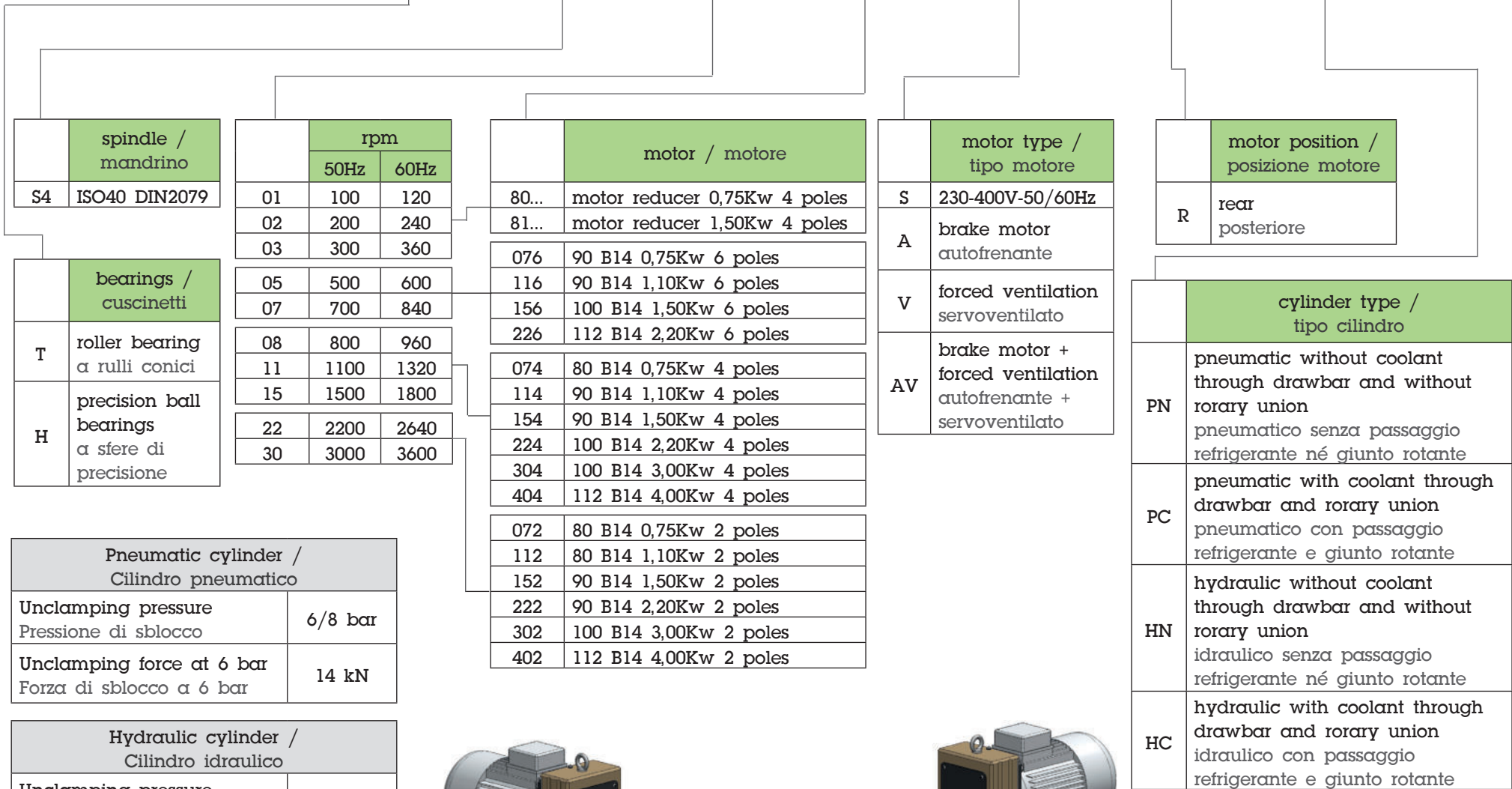



SUA30

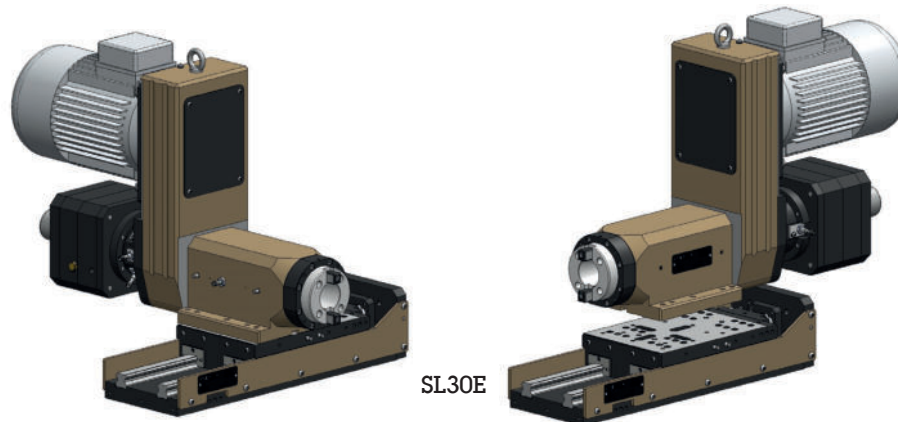

Pneumatic cylinder / Cilindro pneumatico	
Unclamping pressure Pressione di sblocco	6/8 bar
Unclamping force at 6 bar Forza di sblocco a 6 bar	14 kN

Hydraulic cylinder / Cilindro idraulico	
Unclamping pressure Pressione di sblocco	35/40 bar
Unclamping force at 35 bar Forza di sblocco a 35 bar	15 kN



STANDARD COLOR			
	RAL 1001		
OPTIONAL COLORS			
	RAL 1013		RAL 3028
	RAL 1023		RAL 5015
	RAL 2003		RAL 6018