

SUA45

Broche / Werkzeugaufnahme		rpm		Moteur / Motor		Moteur type / Motortyp		Position de moteur / Position des Motors	
		50Hz	60Hz						
S4	ISO40 DIN2079	01	100	120	82...	Motoréducteur 2,20Kw 4 poles Getriebemotor 2,20Kw 4 poles		S	230-400V-50/60Hz
		02	200	240	84...	Motoréducteur 4,00Kw 4 poles Getriebemotor 4,00Kw 4 poles		A	Moteur-frein Bremsmotor
		03	300	360				V	Ventilation forcée Fremdbelüftung
		05	500	600				AV	Moteur-frein + ventilation forcée Bremsmotor + Fremdbelüftung
		08	800	960	116	90 B14 1,10Kw 6 poles		Types de cylindre / Zylindertyp	
		11	1100	1320	156	100 B14 1,50Kw 6 poles		PN	Pneumatique, sans arrosage au centre ni joint tournant Pneumatisch ohne Kühlmittel durch die Zugstange und ohne Drehdurchführung
		15	1500	1800	226	112 B14 2,20Kw 6 poles		PC	Pneumatique, avec arrosage au cen- tre et joint tournant neumatisch mit Kühlmittel durch die Zugstange und mit Drehdurchführung
T	À rouleaux coniques Kegelrollenlager				306	132 B14 3,00Kw 6 poles		HN	Hydraulique, sans arrosage au centre ni joint tournant Hydraulisch ohne Kühlmittel durch die Zugstange und ohne Drehdurchführung
H	À billes de précision Präzisionsschrägbügel- lager	22	2200	2640	406	132 B14 4,00Kw 6 poles		HC	Hydraulique, avec arrosage au centre et joint tournant Hydraulisch mit Kühlmittel durch die Zugstange und mit Drehdurchführung
		30	3000	3600	556	132 B14 5,50Kw 6 poles			
					154	90 B14 1,50Kw 4 poles			
					224	100 B14 2,20Kw 4 poles			
					304	100 B14 3,00Kw 4 poles			
					404	112 B14 4,00Kw 4 poles			
					554	132 B14 5,50Kw 4 poles			
					754	132 B14 7,50Kw 4 poles			
					152	90 B14 1,50Kw 2 poles			
					222	90 B14 2,20Kw 2 poles			
					302	100 B14 3,00Kw 2 poles			
					402	112 B14 4,00Kw 2 poles			
					552	132 B14 5,50Kw 2 poles			
					752	132 B14 7,50Kw 2 poles			

Cylindre pneumatique / Pneumatikzylinder	
Pressions de desserrage Lösedruck	6/8 bar
Effort de desserrage à 6bars Lösekräft bei 6 bar	14 kN

Cylindre hydraulique / Hydraulikzylinder	
Pressions de desserrage Lösedruck	35/40 bar
Effort de desserrage à 35bars Lösekräft bei 35 bar	15 kN

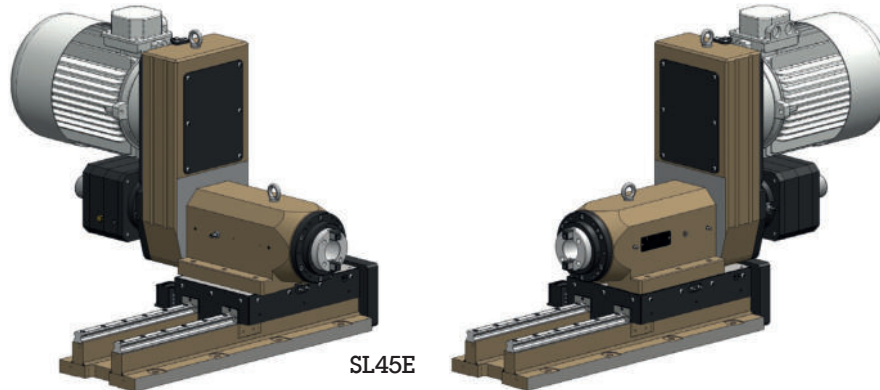







SL45E

STANDARD COLOR

 RAL 1001

OPTIONAL COLORS

	RAL 1013		RAL 3028
	RAL 1023		RAL 5015
	RAL 2003		RAL 6018